

**Junttan**

**Pile Driving Rig**  
PM16

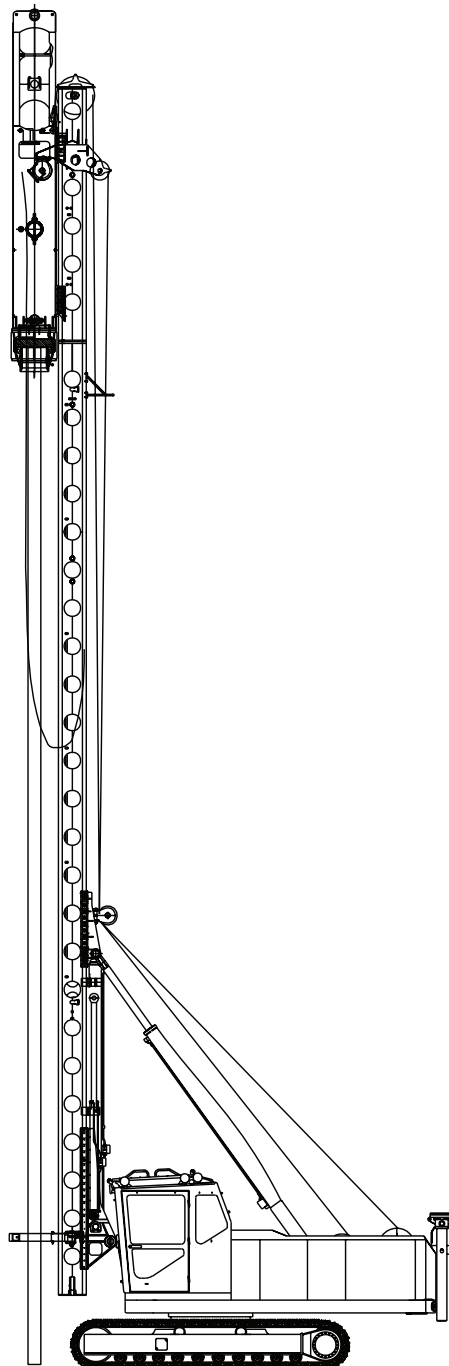

Original  
Junttan  
product

**DATA SHEET**

## General Information

**Junttan PM16** is the most compact Junttan piling rig designed for pile driving where piles are lighter and shorter. The rig can be used for driving timber, concrete and different types of steel piles. The recommended hammer ram weight is from 3 000 to 4 000 kg and the maximum pile length is 16 meters (52 ft). The rig has proven productivity due to excellent mobility, easy and fast handling of piles and top pile driving performance with Junttan hydraulic hammers. An optional side drill or vibrator hammer makes pile driving even more efficient in some soil conditions. With optional Junttan equipment, optimised working set-up of the rig can be easily achieved.

This compact and agile Junttan piling rig has the same proven features as the heavier Junttan machines. Its rugged design makes it a safe and reliable rig even in the most demanding working conditions. The self-erecting leader and many advanced technical features ensure that the rig is ready to work in just a few minutes. The ergonomic and safety tested cabin allows the driver to concentrate completely on his work. The expandable tracks and low centre of gravity make the rig exceptionally stable in different working situations. The horizontal movement of the leader ensures fast spotting of the pile. Because of the lightweight construction and compact size, the rig can be easily transported to a new working site.

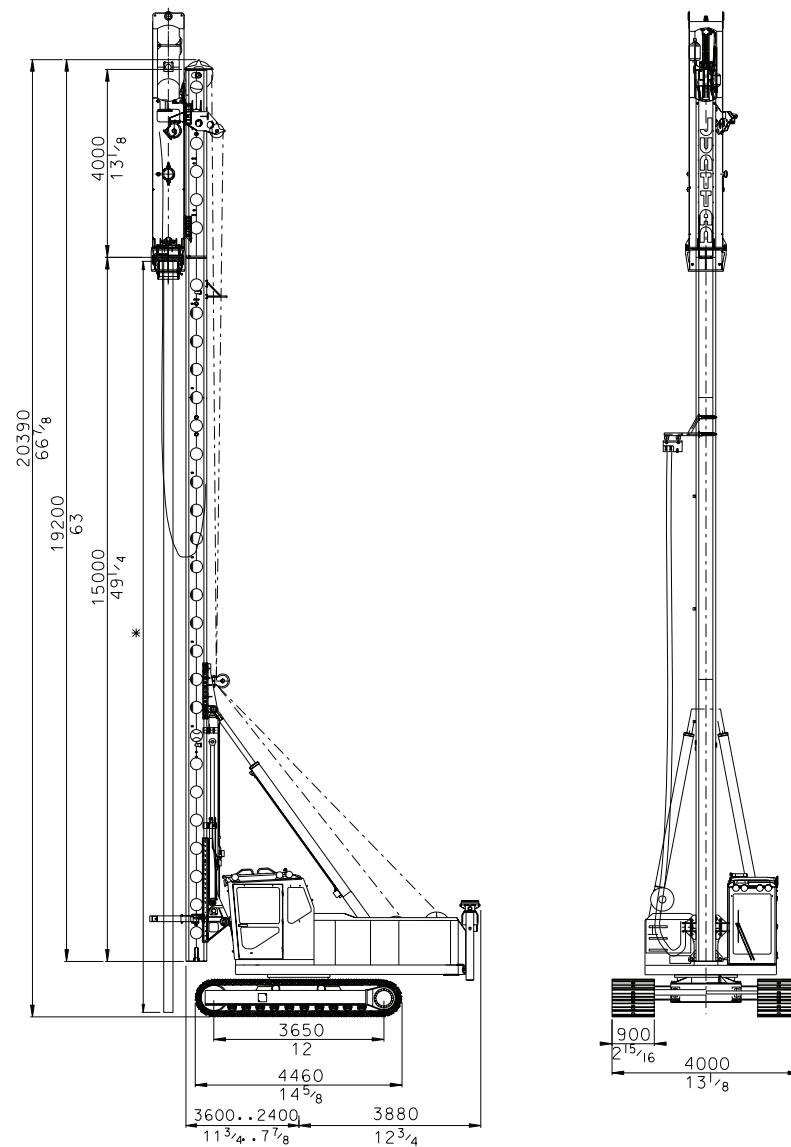

\* Pile length depends on the hammer.

# Technical Data

## Basic features

Nominal operational weight		37 000 kg	86 000 lb
Leader capacity		12 000 kg	21 500 lb
Winch capacity	Pile:	5 000 kg	11 000 lb
	Hammer:	8 000 kg	17 600 lb
Recommended hammer type		HHK 3-4A	HHK 3-4A
Maximum pile length (HHK 3-4A)		16 m	52 ft

## Uppercarriage

Engine	Type:	Cummins QSB6,7	
	Power:	179 kW	240 hp
	Fuel tank:	600 liters	158 gal
Hydraulic system	Max flow:	2x160 + 86 lpm/2000rpm	2x42 + 23 gpm/2 000rpm
	Max pressure:	320 bar	4 640 psi
	Oil tank:	450 liters	119 gal
Cabin	Air conditioned safety cabin		

## Leader

Type	Fixed PM16		
Movements	Foot (up/down)	1 200/300 mm	47/12 in
	Horizontal	1 200 mm	47 in
Inclinations	According separate capacity tables Electronic inclinometer included		

## Undercarriage

Type	JV45138		
Crawler length	4 460 mm		176 in
Width (900 shoes)	Min:	3 000 mm	118 in
	Max:	4 000 mm	157 in
Track shoe options	Width:	800/900 mm	31½/35½ in
	Surface:	3-edge / flat edges / flat	
	Edge type:	normal / chamfer / bended	

## Accessories

* Side cathead		* iPiler PCD
* Side auger	JD1,5	* Leader hinge
* Rear support legs		* Automatic lubrication system

\* Contact Junttan sales for all available options and accessories

# Transport Dimension

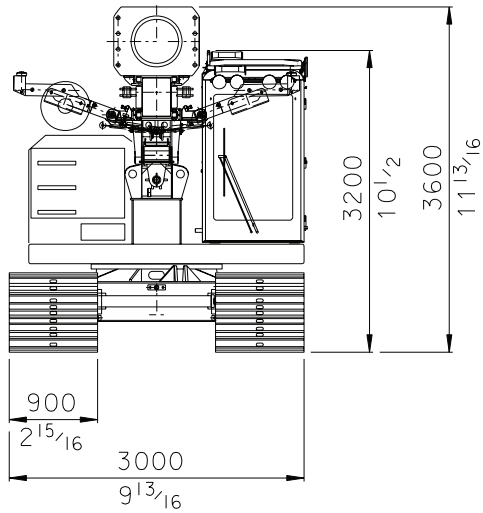

**Minimum track width.**

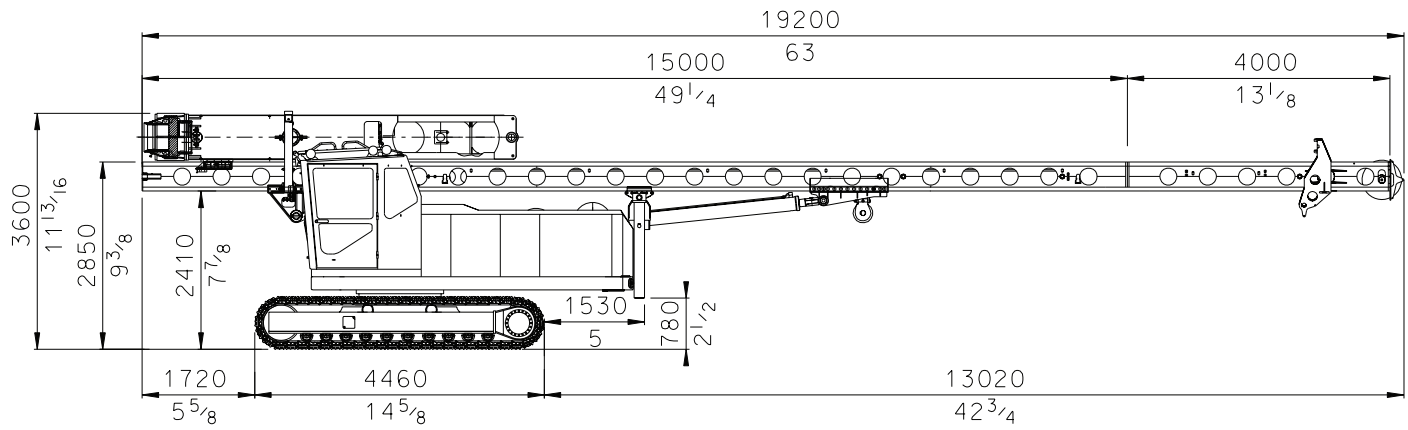

**JUNTAN PM16 with HHK 3A hammer transport dimensions with the standard leader.**

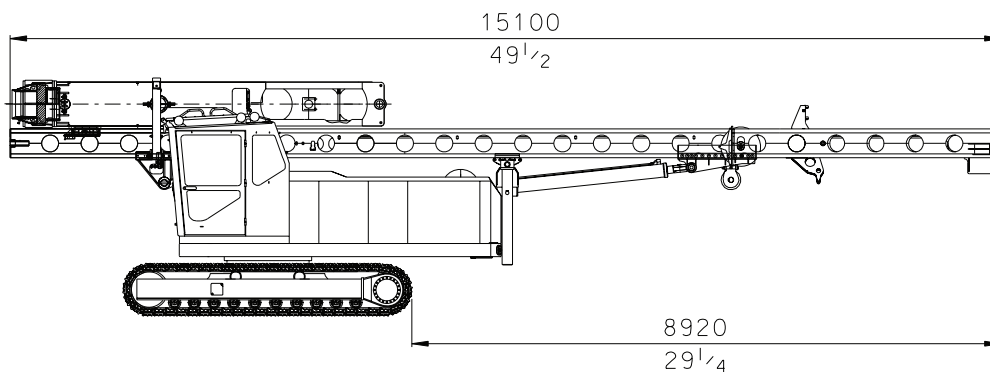

**JUNTAN PM16 with HHK 3A hammer transport dimensions, leader equipped with hinge.**

**Junttan**

**Junttan Oy**  
P.O. Box 1702 (Matkuksentie 7)  
FI-70701 KUOPIO, Finland

Tel. +358 10 195 221  
Fax +358 17 287 4411  
junttan@junttan.com